

# One Cell Lithium-ion/Polymer Battery Protection IC

## ■ General Description

The LN8243 provides a high integration solution for lithium-ion/polymer battery protection. The LN8243 contains advanced power MOSFET, high-accuracy voltage detection circuits and delay circuits.

The LN8243 has all the protection functions required in the battery application including over-charging, over-discharging, over-current and load short circuiting protection etc. The low standby current drains little current from the cell while in storage.

The device is targeted for any Li-Ion and Li-Poly battery-powered information appliances requiring long-term battery life.

## ■ Package

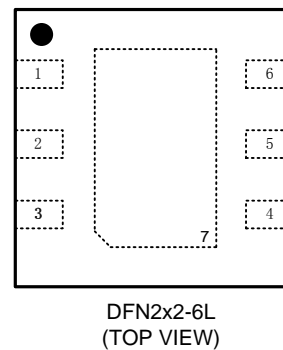
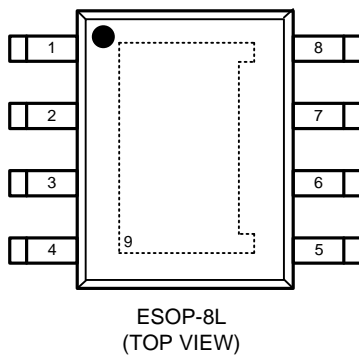

## ■ Application Information

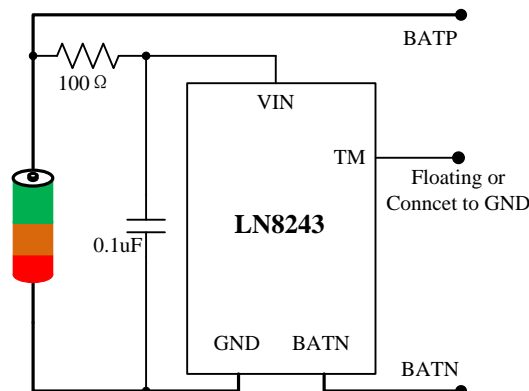

## ■ Features

- Protection of Charger Reverse Connection
- Protection of Battery Cell Reverse Connection
- High-accuracy Voltage Detection
- Charger Detection Function
- 0V Battery Charging Enable/Disable Function
- Integrate Advanced Power MOSFET(20mΩ)
- Low Current Consumption  
 Operation Mode: 3.0μA typ.  
 Power-down Mode: 0.1μA max.

## ■ Application

- One-Cell Lithium-ion Battery Pack
- Lithium-Polymer Battery Pack

**■ Functional Pin Description**

Pin Name	ESOP8-8L	DFN2x2-6L	Note
BATN	1	4	The negative terminal of battery pack
BATN	2	5	The negative terminal of battery pack
BATN	3	6	The negative terminal of battery pack
BATN	4	-	The negative terminal of battery pack
VIN	5	1	Power Supply
GND	6	2	Ground
GND	7	3	Ground
TM	8	-	Test terminal
Heatsink	9	-	Heatsink must be connected to GND
	-	7	Heatsink must be connected to BATN

**■ Ordering Information**
**LN8243 ①②③④ - ⑤**

Designator	Symbol	Description
①	L	4.20V Battery Over Voltage Protect
	H	4.35V Battery Over Voltage Protect
②	6	7A Discharge Current Protect
③	E	ESOP-8L Package
	D	DFN2x2-6L Package
④	R	Reel
	T	Tape
⑤	G	

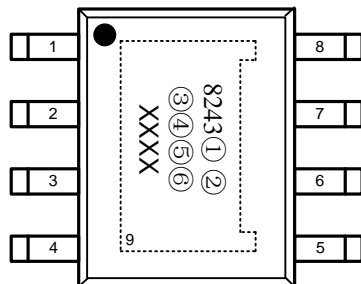
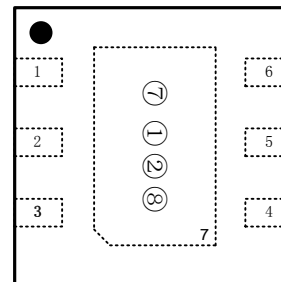
**■ Marking Information**

 ESOP-8L  
 (TOP VIEW)

 DFN2x2-6L  
 (TOP VIEW)

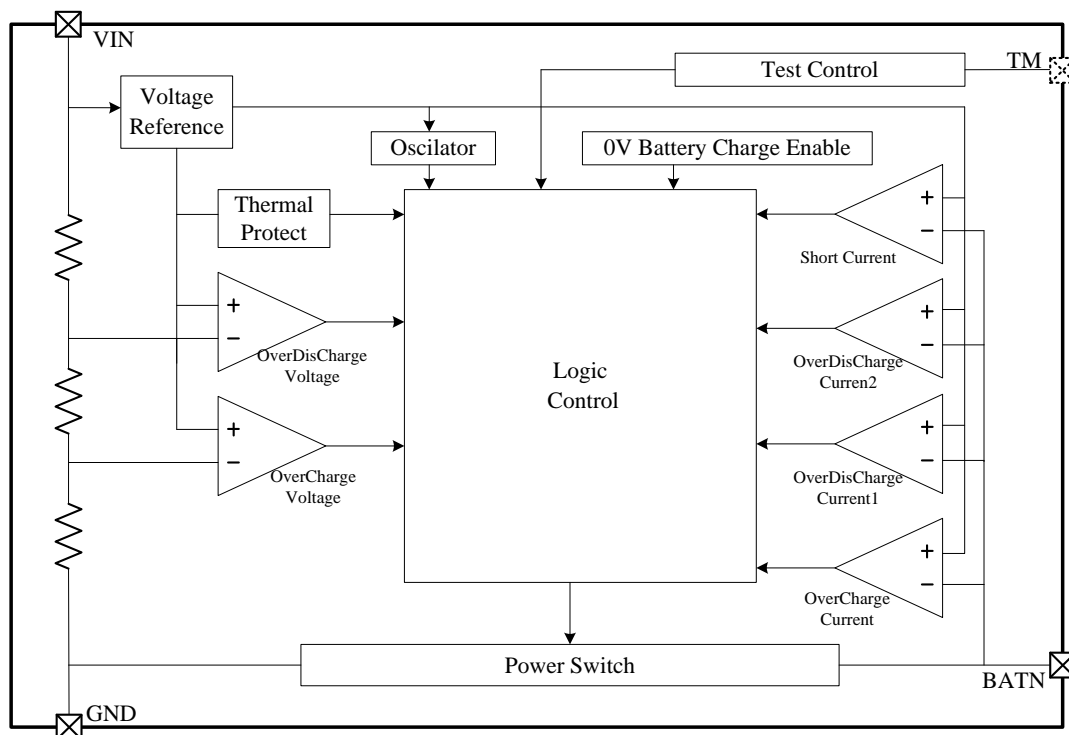
标号	标记	描述
①	A	4.20V Battery Protect
	B	4.35V Battery Protect
②	A	7A Discharge Protect
③④⑤⑥		Production Information
⑦	7	LN8243
⑧	D	DFN2x2-6L
XXXX	Tracking information for internal quality	

### ■ Function Block Diagram



### ■ Absolute Maximum Ratings

Parameter	Symbol	Max	Unit
Supply Voltage	VIN	GND-0.3~GND+6.0	V
Power Dissipation	PD@TA=25℃	0.4	W
Package Thermal Resistance(Junction to Ambient)		130	℃/W
Lead Temperature		260	℃
Ambient Temperature	Topa	-40~+85	
Storage Temperature	Tstr	-55~+125	
ESD Susceptibility	HBM	4000	V

**■ Electrical Characteristics**

 Note:  $V_{VIN} = 3.5V$ ,  $T_A = 25^\circ C$ , unless otherwise specification.

Parameters	Test Condition	Min	Typ	Max	Unit
<b>Voltage</b>					
Over-Charge Detection Voltage		4.25	4.28	4.31	V
Over-Charge Release Voltage		4.12	4.15	4.18	V
Over-Charge Detection Voltage (*)			4.45		V
Over-Charge Release Voltage(*)			4.25		V
Over-Discharge Detection Voltage		2.46	2.50	2.54	V
Over-Discharge Release Voltage		2.96	3.00	3.04	V
Charger Detection Voltage			-0.50		V
<b>Current</b>					
Over-Discharge Current Detection 1	$V_{DD} = 3.5V$		7.0		A
Over-Discharge Current Detection 2	$V_{DD} = 3.5V$		10		A
Load Short Detection	$V_{DD} = 3.5V$		20		A
Normal Operator Current	$V_{DD} = 3.5V$ , $V_{BATN} = 0V$		3.0	6	$\mu A$
Power Down Current	$V_{DD} = 2.0V$ , BATN floating			0.1	$\mu A$
<b>Delay Time</b>					
Over-Charge Voltage Detection Delay Time			200		mS
Over-Discharge Voltage Detection Delay Time			50		mS
Over-Discharge Current Detection 1 Delay Time			12		mS
Over-Discharge Current Detection 2 Delay Time			2.5		mS
Load Short Detection Delay Time			40		$\mu S$
<b>BATN Internal Resistance</b>					
Internal Resistance between BATN and $V_{DD}$	$V_{DD} = 3.5V$ BATN=1.0V		320		$k\Omega$
Internal Resistance between BATN and GND	$V_{DD} = 2.0V$ BATN=1.0V		100		$k\Omega$
Power FET on Resistance	$V_{DD} = 4.0V$ , $I_{BATN} = 1.0A$		20		$m\Omega$
Over Temperature Protection			100		$^\circ C$
Over Temperature Hybrid			20		$^\circ C$
Note: Parameter with * is used for 4.35V Battery Protect, Other is for 4.2V Battery Protect					

## ■ Typical Operating Characteristics

The LN8243 monitors the voltage and current of a battery and protects it from being damaged due to overcharge voltage, over-discharge voltage, over-discharge current, and short circuit conditions by disconnecting the battery from the load or charger. These functions are required in order to operate the battery cell within specified limits.

### Normal operating mode

If no exception condition is detected, charging and discharging can be carried out freely. This condition is called the normal operating mode.

### Over-Charge Condition

When the battery voltage becomes higher than the over-charge detection voltage ( $V_{CU}$ ) during charging under normal condition and the state continues for the overcharge detection delay time ( $t_{CU}$ ) or longer, the LN8243 turns off the power switch FET.

### Over-Discharge Condition

When the battery voltage drops below the over-discharge detection voltage ( $V_{DL}$ ) during discharging under normal condition and it continues for the over-discharge detection delay time ( $t_{DL}$ ) or longer, the LN8243 turns off the power switch FET and stops discharging. After over-discharging condition, the BATN pin is pulled up to high state by the internal control of LN8243, the current of the chip is reduced to the power-down current ( $I_{PDN}$ ).

At the over-discharge condition, when a charger is connected, the power switch FET is still off. At this time, charging is still permitted through the parasitic diode of the power switch FET, when the battery voltage becomes higher than the over-discharge detection voltage ( $V_{DL}$ ), the LN8243 turns on the power switch FET and changes to the normal condition from the over-discharge condition.

### Over-Current Condition

When the discharging current becomes equal to or higher than a specified value during discharging under normal condition and the state continues for the over-current detection delay time or longer, the LN8243 turns off power switch FET to stop discharging, and the BATN pin is pulled up to high state by the internal control of LN8243. This condition includes over-current1, over-current2 or load short-circuiting.

The over-current condition returns to the normal mode when the load is released or the impedance between BATH and BATN is larger than 500k $\Omega$ .

The LN8243 provides two over-current detection levels (7A and 10A) with two over-current delay time ( $T_{OI1}$  and  $T_{OI2}$ ) corresponding to each over-current detection level.

### Delay Circuits

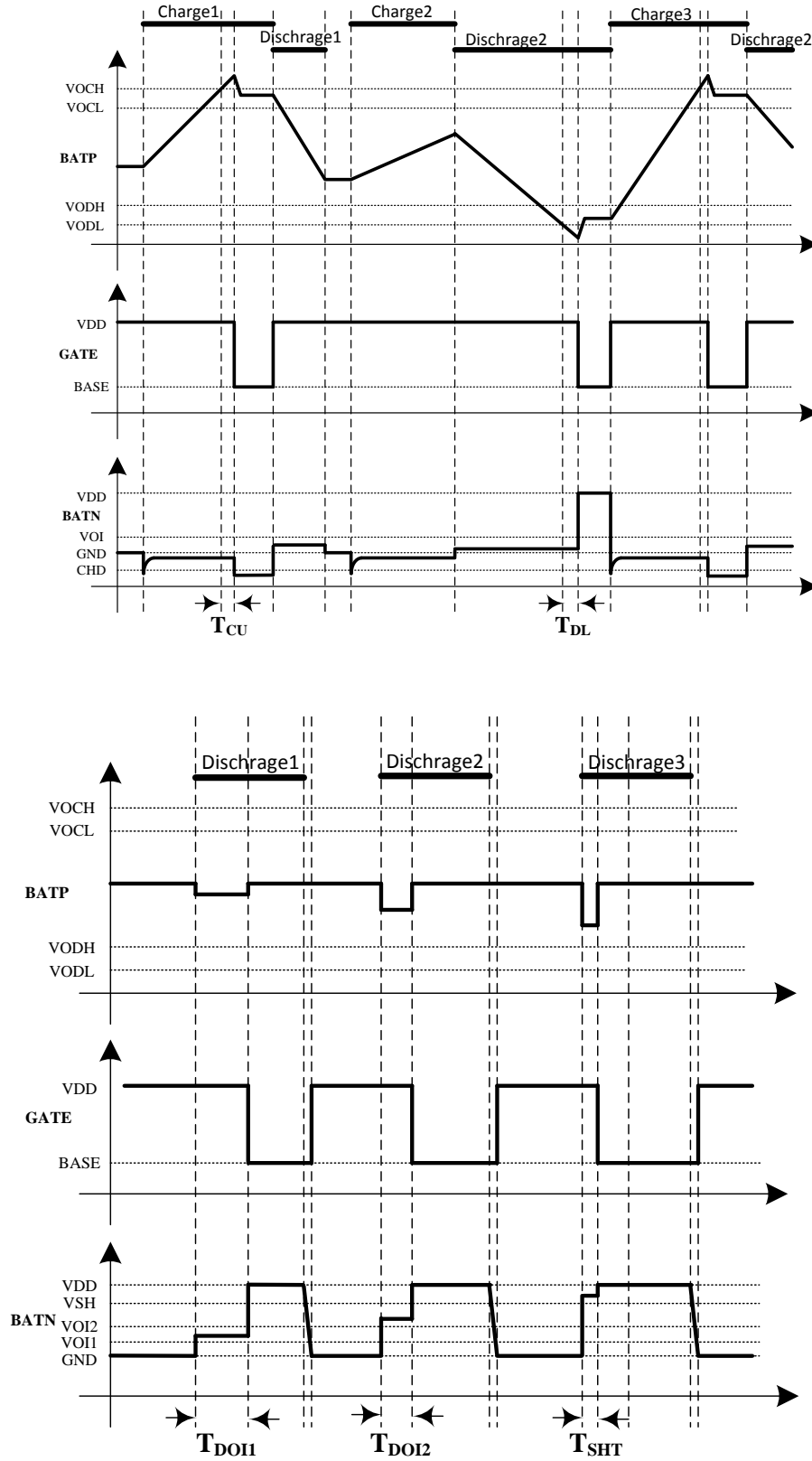

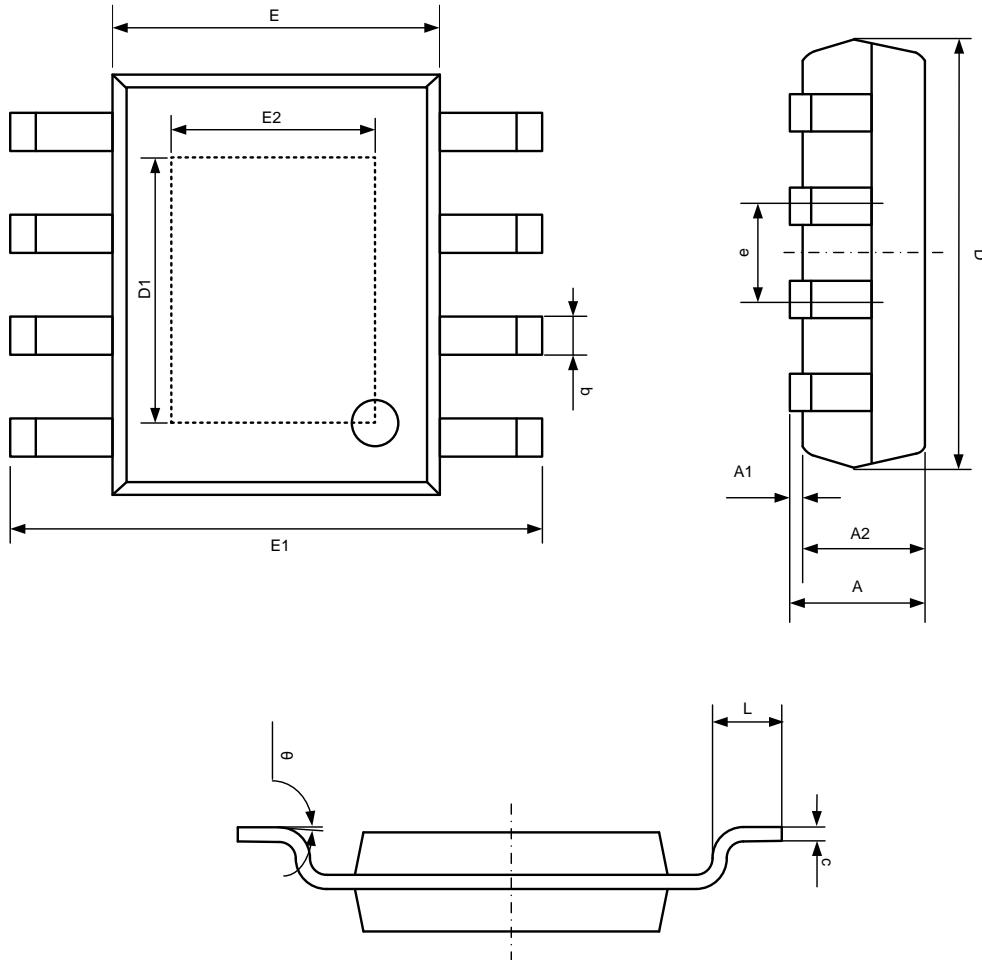
**Package Information**
**ESOP-8L**

Symbol	Dimensions In Millimeters		Dimensions In Inches	
	Min	Max	Min	Max
A	1.350	1.750	0.053	0.069
A1	0.050	0.150	0.002	0.006
A2	1.350	1.550	0.053	0.061
b	0.330	0.510	0.013	0.020
c	0.170	0.250	0.007	0.010
D	4.700	5.100	0.185	0.200
D1	3.202	3.420	0.126	0.134
E	3.800	4.000	0.150	0.157
E1	5.800	6.200	0.228	0.244
E2	2.313	2.513	0.091	0.099
e	1.270(BSC)		0.050(BSC)	
L	0.400	1.270	0.016	0.050
$\theta$	0°	8°	0°	8°

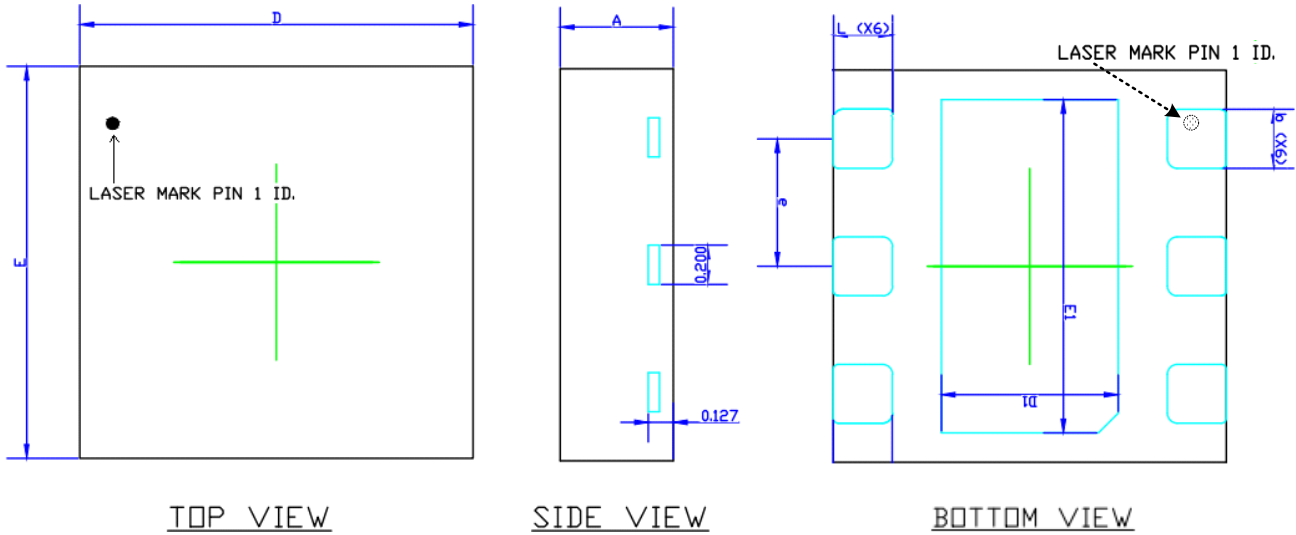
**DFN2x2-6L**

COMMON DIMENSION (MM)			
PKG	DFN2020-6L		
SYMBOL	MIN.	NOM.	MAX
A	0.527	0.552	0.577
b	0.20	0.25	0.30
D	1.90	2.00	2.10
E	1.90	2.00	2.10
D1	0.80	0.90	1.00
E1	1.60	1.70	1.80
e	0.65 REF.		
L	0.25	0.30	0.35