

## 70mΩ, 3A Smart Universal Power Switch with Flag

### General Description

The LN9703 is a low voltage, high performance single N-MOSFET power switch, designed for power rail on/off control with low  $R_{DS(ON)} \approx 70m\Omega$  and full protection functions. The LN9703 equipped with a charge pump circuitry to drive the internal MOSFET switch and a flag output is available to indicate fault conditions against large di/dt which may cause the supply to fall out of regulation. In order to fit different application, an ISET pin is offered for current limit point setting, a resistor from ISET to ground sets the current limit for the switch.

Additional features include soft-start to limit inrush current during plug-in, thermal shutdown to prevent catastrophic switch failure from high-current loads, Output anti back irrigation Protection whether EN pin is connected GND or VIN, under-voltage lockout (UVLO) to ensure that the device remains off unless there is a valid input voltage present, a precision resistor-programmable output current limit up to 3.5A. Besides, the lower quiescent current as 40μA making this device ideal for portable battery-operated equipment.

The LN9703 is available in SOT23-5 or SOP-8 package requiring minimum board space and smallest components.

### Applications

- USB 3G Datacard
- USB Dongle
- MiniPCI Accessories
- LCD Monitor, LCD-TV
- USB Power Module for ADSL
- Information Appliance and Set-Top Box
- Battery-Powered Equipment
- Hot-Plug Power Supplies
- ACPI Power Distribution
- PCI Bus Power Switching
- Motherboard & Notebook PCs
- PC Card Hot Swap Application

### Features

- Adjustable Current Limiting up to 3.5A
- Built-In (Typically 70mΩ) N-MOSFET
- Reverse Current Flow Blocking (no body diode)
- Output Can Be Forced Higher than Input (Off or On State)
- Low Supply Current :  
-----40μA Typical at Switch on State  
-----Less than 1μA Typical at Switch Off State
- Guaranteed Continuous Load Current  
-----LN9703MR (SOT23-5) : 2.1A  
-----LN9703SR (SOP-8) : 3A
- Wide Input Voltage Ranges : 2V to 5.5V
- Open-Drain Fault Flag Output
- Hot Plug-In Application (Soft-Start)
- 1.7V Typical Under-Voltage Lockout (UVLO)
- Thermal Shutdown Protection
- Smallest SOT23-5 and SOP-8 Package
- RoHS Compliant and 100% Lead (Pb)-Free

### Pin and Marking

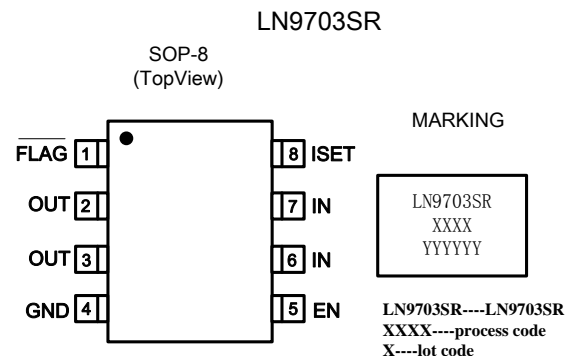
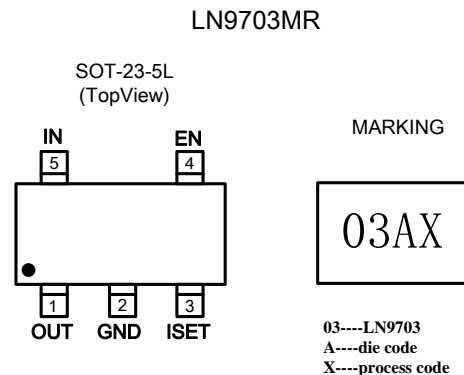

## Typical Application Circuit

Circuit 1:

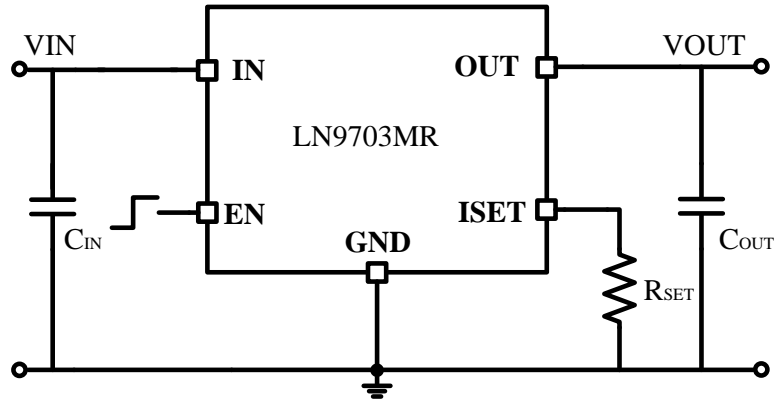

Circuit 2:

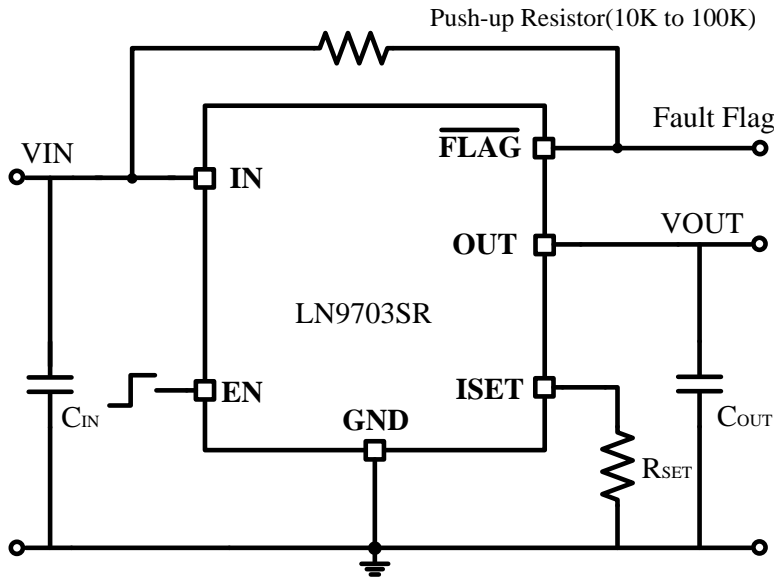

Note: Current limit:  $I_{LIMIT} = 270K/R_{SET}$ .

## Functional Pin Description

Pin Name	Pin Function
IN	Power Input Voltage.
OUT	Output Voltage.
GND	Ground.
EN	Chip Enable (Active High).
ISET	Current Limit Programming Input.
$\overline{\text{FLAG}}$	Open-Drain Fault Flag Output.

## ■ Absolute Maximum Ratings

- Supply Voltage ----- 6.5V
- Chip Enable Input Voltage ----- -0.3V to 6.5V
- Flag Voltage----- 6.5V
- Power Dissipation, PD @ TA = 25 °C  
 SOT23-5----- 0.6W  
 SOP-8 ----- 0.95W
- Package Thermal Resistance  
 SOT23-5-----200 °C/W  
 SOP-8,  $\theta_{JA}$  -----104 °C/W
- Junction Temperature -----125°C
- Lead Temperature (Soldering, 10 sec.) -----260°C
- Storage Temperature Range ----- -65°C to 150°C
- ESD Susceptibility (Note 2)  
 HBM (Human Body Mode) -----8kV  
 MM (Machine Mode) ----- 800V

## ■ Electrical Characteristics

(VS = +5V, VCM = +2.5V, VO = +2.5V, TA = +25°C, unless otherwise noted.)

Symbol	Parameter	Conditions	Min.	Typ.	Max.	Unit
R <sub>DS(ON)</sub>	Switch On Resistance	I <sub>OUT</sub> = 1A		70	80	mΩ
I <sub>SW_ON</sub>	Supply Current	Switch On, V <sub>OUT</sub> = Open		40	50	μA
I <sub>SW_OFF</sub>	Shutdown Current	Switch Off, V <sub>OUT</sub> = Open		0.1	1	μA
V <sub>IL</sub>	CE Threshold Logic-Low Voltage	Switch Off			0.8	V
V <sub>IH</sub>	CE Threshold Logic-High Voltage	Switch On	2.0			V
I <sub>CE</sub>	CE Input Current	V <sub>CE</sub> = 0V to 5.5V		10		pA
I <sub>LEAKAGE</sub>	Output Leakage Current	V <sub>CE</sub> = 0V, R <sub>LOAD</sub> = 0Ω		0.5		μA
T <sub>ON_RISE</sub>	Output Turn-On Rise Time	10% to 90% of V <sub>OUT</sub> rising		1.5		ms
	Current Limit Factor	I <sub>LIM</sub> × R <sub>SET</sub>		270k		A·Ω
I <sub>LIMSET</sub>	Max. Current Limit Setting	V <sub>IN</sub> =3.3V to 5.5V, R <sub>SET</sub> =75kΩ			3.5	A
ΔI <sub>LIMSET</sub>	Current Limit Setting Accuracy	I <sub>LIMSET</sub> = 0.5A to 3A (R <sub>SET</sub> = 540kΩ to 90kΩ)	-20		+20	%
R <sub>FLG</sub>	FLAG Output Resistance	I <sub>SINK</sub> = 1mA		15	400	Ω
I <sub>FLG_OFF</sub>	FLAG Off Current	V <sub>FLG</sub> = 5V		10		nA
t <sub>D</sub>	FLAG Delay Time	Form fault condition to FLAG assertion	2	4.6	8	ms
V <sub>UVLO</sub>	Under-Voltage Lockout	V <sub>IN</sub> increasing	1.3	1.7		V
ΔV <sub>UVLO</sub>	Under-Voltage Hysteresis	V <sub>IN</sub> decreasing		0.1		V
T <sub>SD</sub>	Thermal Shutdown Protection			120		°C
ΔT <sub>SD</sub>	Thermal Shutdown Hysteresis			30		°C

Package Information

SOT-23-5L

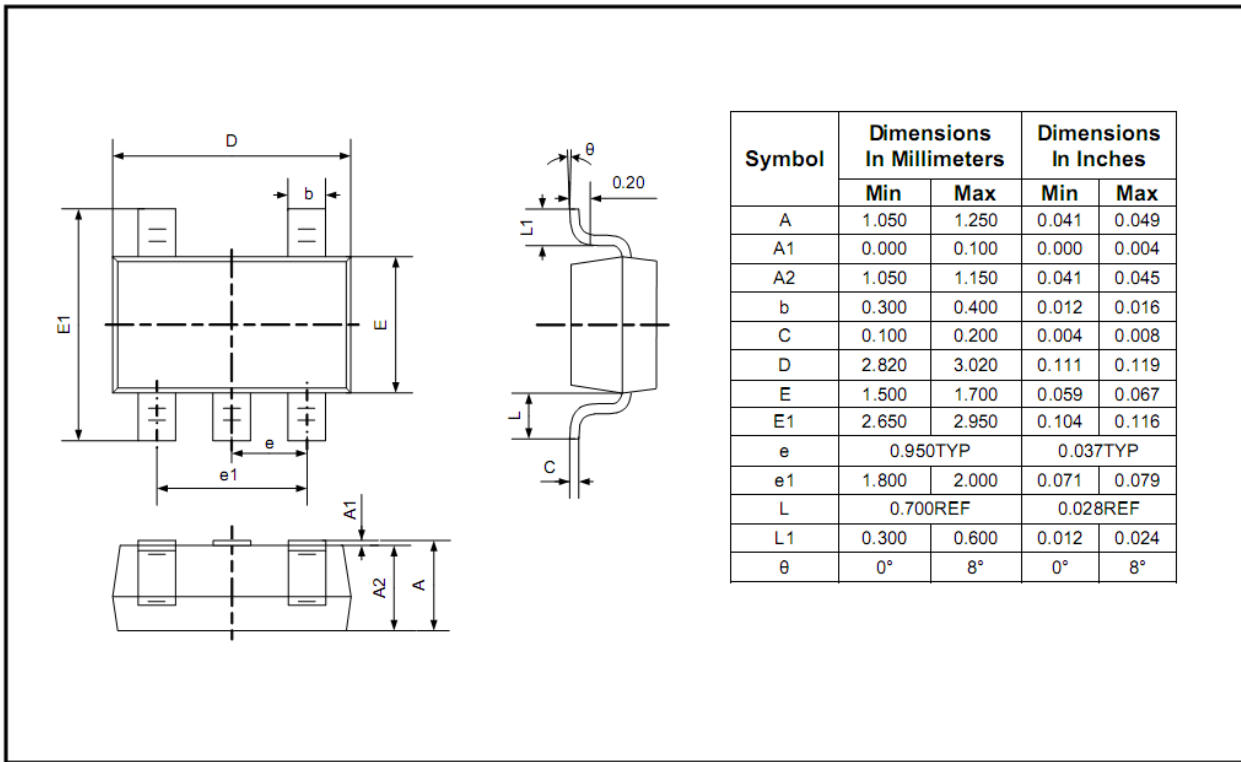

SOP8

