



## Over Voltage and Over Current Protection IC

### General Description

The LP5305A is a highly integrated circuits, it used to protect low voltage system from abnormal high input voltage. The IC continuously check the input voltage, the input current, and the battery voltage. When the protection status is occur, the power MOS will turn off at the same time. The LP5305A is safety devices to ensure worked against accidents.

In case of the input voltage exceeds a OVP threshold voltage level, the power MOS will turn off within 1 $\mu$ s. The current limit can is adjustable by external resistor between ISET and GND. And the current is also limited to prevent charging the battery with an excessive current. The LP5305A also monitors the Li-ion battery voltage, when the battery voltage exceeds 4.35V, the IC will turn off the MOS.

Other features include over temperature protection and under-voltage lockout (UVLO). The LP5305A is available in a space saving DFN-8 package.

### Order Information

LP5305A □ □ □  
F: Green  
Package Type  
QV: DFN-8

### Features

- ◆ Withstand High Input Voltage Up to 26V
- ◆ Adjustable Over Current Protection
- ◆ Input Over Voltage Protection
- ◆ Battery Over Voltage Protection
- ◆ High Accuracy Protection Thresholds
- ◆ Fault Signal Output
- ◆ Enable Control
- ◆ Under Voltage Lockout
- ◆ Output Short-Circuit Protection
- ◆ Over-Temperature Protection
- ◆ Available in DFN-8
- ◆ RoHS Compliant and Halogen Free

### Applications

- ◆ Cell Phones
- ◆ Digital Cameras
- ◆ Portable Instruments

### Marking Information

Device	Marking	Package	Shipping
LP5305A	LPS P5305A YWX	DFN-8	4K/REEL

Y: Y is year code. W: W is week code. X: X is series number.



## Typical Application Circuit

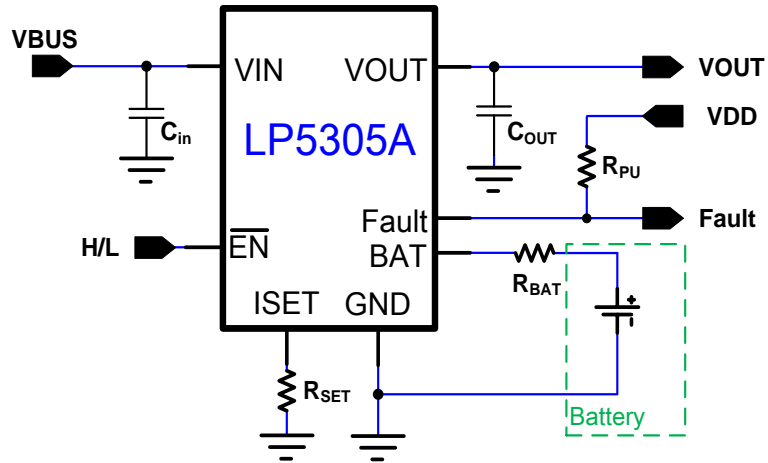

Figure 1. Typical Application Circuit of LP5305A .

## Pin Configuration

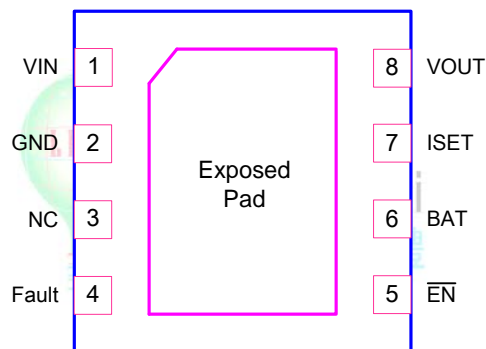

Figure 2. Package Top View



## Function Block Diagram

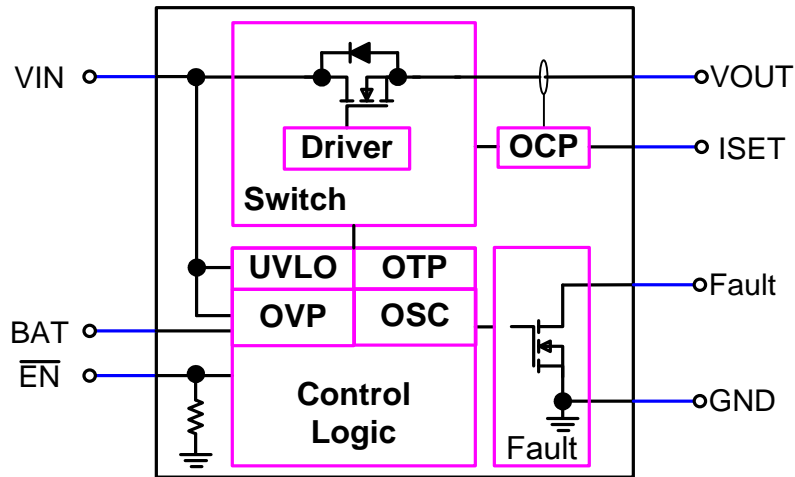

Figure 3. Function Block Diagram

## Functional Pin Description

Pin NO.	DFN8	Description
VIN	1	Power source input. Connect a ceramic capacitor between VIN and GND.
GND	2	Ground.
NC	3	No connect.
Fault	4	Fault output pin. Open-drain output, device status.
$\overline{\text{EN}}$	5	Enable pin.
BAT	6	Battery voltage detector input.
ISET	7	OCP level setting by an external resistor to GND.
VOUT	8	Output through the power MOSFET.
	EP	Exposed pad. Connect EP to GND is suggested.



## Absolute Maximum Ratings <sup>Note1</sup>

◇ VIN to GND	-----	-0.3V to +30V
◇ VOUT to GND	-----	-0.3V to +7V
◇ All Other Pin to GND	-----	-0.3V to +7V
◇ Operating Junction Temperature Range (T <sub>J</sub> )	-----	-40°C to 150°C
◇ Operation Ambient Temperature Range	-----	-40°C to +105°C
◇ Storage Temperature Range	-----	-65°C to +150°C
◇ Maximum Soldering Temperature (at leads, 10sec)	-----	+260°C

**Note1.** Stresses beyond those listed under “Absolute Maximum Ratings” may cause permanent damage to the device. These are stress ratings only, and functional operation of the device at these or any other conditions beyond those indicated in the operational sections of the specifications is not implied. Exposure to absolute maximum rating conditions for extended periods may affect device reliability.

## Thermal Information

◇ Thermal Resistance		
DFN-8, $\theta_{JA}$	-----	76.11 °C/W
DFN-8, $\theta_{JC}$	-----	68.46 °C/W

## Recommended Operating Conditions

◇ Input Voltage, V <sub>IN</sub>	-----	3.3V to 5V
◇ Output Current, I <sub>OUT</sub>	-----	0.3A to 1.5A
◇ OCP Set Resistance, R <sub>SET</sub>	-----	15k $\Omega$ to 90k $\Omega$
◇ Junction Temperature, T <sub>J</sub>	-----	-40°C to 125°C



## Electrical Characteristics

( $V_{IN} = 5V$ ,  $T_A = 25^\circ C$ , Unless Otherwise Specified)

Parameter	Symbol	Test Conditions	Min	Typ	Max	Units
<b>General Function</b>						
Power Source Voltage	$V_{IN}$	$T_J = +25^\circ C$	3.3	5	26	V
Input UVLO Threshold	$V_{UVLO}$	$V_{IN}$ Rising	2.5	2.7	2.9	V
UVLO Threshold Hysteresis	$\Delta V_{UVLO}$	Falling Hysteresis		200		mV
Power On Deglitch Time	$T_{Deglitch}$			8		ms
Soft Start Time	$T_{SS}$			8.2		ms
Power Source Current	$I_{IN}$	$V_{IN}=5V, \overline{EN}=L$		400		$\mu A$
Shutdown Current	$I_{SD}$	$V_{IN}=5V, \overline{EN}=H$		55		$\mu A$
Thermal Shutdown Threshold	$T_{SD}$			140		$^\circ C$
Thermal Shutdown Threshold Hysteresis	$\Delta T_{SD}$			20		$^\circ C$
<b>Logic Function</b>						
$\overline{EN}$ Threshold Voltage	$V_{ENH}$		1.4			V
	$V_{ENL}$				0.4	V
$\overline{EN}$ Input Resistance to GND	$R_{IEN}$	$\overline{EN}=2V$		15		$\mu A$
FAULT Output Logic Low		Sink 5mA		0.2		V
FAULT Logic High Leakage Current		Fault=5V			10	$\mu A$
<b>Power MOS</b>						
Switch On Resistance	$R_{DS(ON)}$	$I_{OUT}=1A$		160	250	m $\Omega$
<b>Regulation Function</b>						
Output Voltage Regulation	$V_{LDO}$	$V_{IN}=5.7V$		5.1		V
<b>Protection Functions</b>						
Input Over Voltage Protect threshold	$V_{IOVP}$	$V_{IN}$ from 5V to 10V		6.8		V
Input OVP threshold Hysteresis	$\Delta V_{IOVP}$	$V_{IN}$ from 10V to 5V		100		mV
Input OVP Recovery Delay Time	$T_{OVPR}$			8.2		ms
Over Current Protection	$I_{OCP}$	$R_{SET} = 24.9K,$ $3.3V < V_{IN} < V_{IOVP}$		1		A
OCP Blanking Time	$T_{OCP}$			200		$\mu s$
Over Current Recover Delay	$T_{OCR}$			65		ms
Battery Voltage OVP	$V_{BOVP}$	$V_{IN}=5V$		4.35		V
Battery OVP Hysteresis	$\Delta V_{BOVP}$	$V_{IN}=5V$		0.275		V
Battery OVP Blanking Time	$T_{BOVP}$	$V_{IN}=5V$		200		$\mu s$
BAT Pin Leakage Current	$I_{BAT}$	$V_{IN}=5V, V_{BAT}=4.4V$			10	nA



## Application Information

The LP5305A devices monitor the input voltage, battery voltage, and output current to protect the charging system of a Li-Ion battery. When enabled, the system is protected against input overvoltage by turning off an internal switch, immediately removing power from the charging circuit. For an over-current condition, the device limits the output current at the setting value, and if the over-current persists, the switch will turn off after a blanking time. Additionally, the device also monitors its own temperature and switches off if device too hot..

### Under Voltage Lockout (UVLO)

The LP5305A had an UVLO internal circuit that enable the device once the voltage on the  $V_{IN}$  voltage exceeds the UVLO threshold voltage.

### Input Over Voltage Protection

The LP5305A Input has an over voltage protection to protect the battery charging system. When the  $V_{IN}$  voltage rises above 5.1V(Typ.), the system will turns the switch off.

### Battery Over Voltage Protection

The battery overvoltage threshold  $V_{BOVP}$  is internally set to 4.35V. If the battery voltage exceeds the threshold, the switch is turned off, and the Fault pin is go low. Once the battery voltage drops to  $(V_{BOVP} - \Delta V_{BOVP})$ , the switch is turned back on. And the switch is turned off permanently, when battery overvoltage occurs 15 times in one charge cycle. For cleared this event, the  $V_{IN}$  power or EN need to re-cycled.

### Over Temperature Protection

The LP5305A device enters over temperature protection(OTP) if its junction temperature exceeds 140°C (Typ.). During over temperature protection none of the device's functions are available. To resume normal operation the junction temperature need cool down, and the outputs will restart.

### Enable Control

The LP5305A has an enable pin which can be used to enable or disable the device. When the EN pin is driven high, the switch is turned off. The EN pin has an internal pull-down resistor can be floating.

### Fault Flag

The FAULT pin is open-drain output.

- Input Over Voltage
- Output Over Current
- Battery Over Voltage
- Over Temperature

### Over Current Protection

The Over Current threshold can adjustable by a external resistor RSET connected from the ISET pin to GND. The equation is apply under below:

$$I_{OCP} = 25000 \div R_{SET}$$

If the output current exceed the  $I_{OCP}$  threshold, the device limits the current for a blanking duration of  $T_{OC}$ . If the over current situation exceeds the  $T_{OC}$ , the switch will turned off, and the Fault pin is go low. The switch will re-soft start again after  $T_{OCR}$ . And the switch is turned off permanently, when over current event occurs 15 times in one charge cycle. For cleared this event, the  $V_{IN}$  power or EN need to re-cycled

### Layout Consideration

The proper PCB layout and component placement are critical for all circuit. LP5305A is meant to protect downstream circuit. Here are some suggestions to the layout design.

1. Connected all ground together with one uninterrupted ground plane, which include power ground and analog ground.
2. The input and output capacitor should be located as closed as possible to the chip and ground plane.
3. Other components should be located close to the chip.

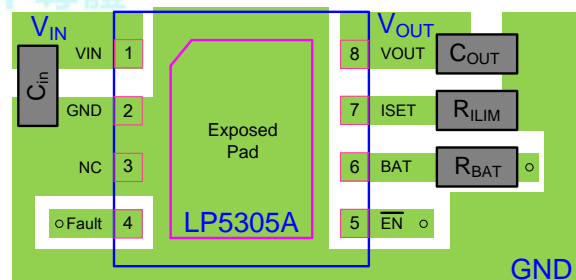
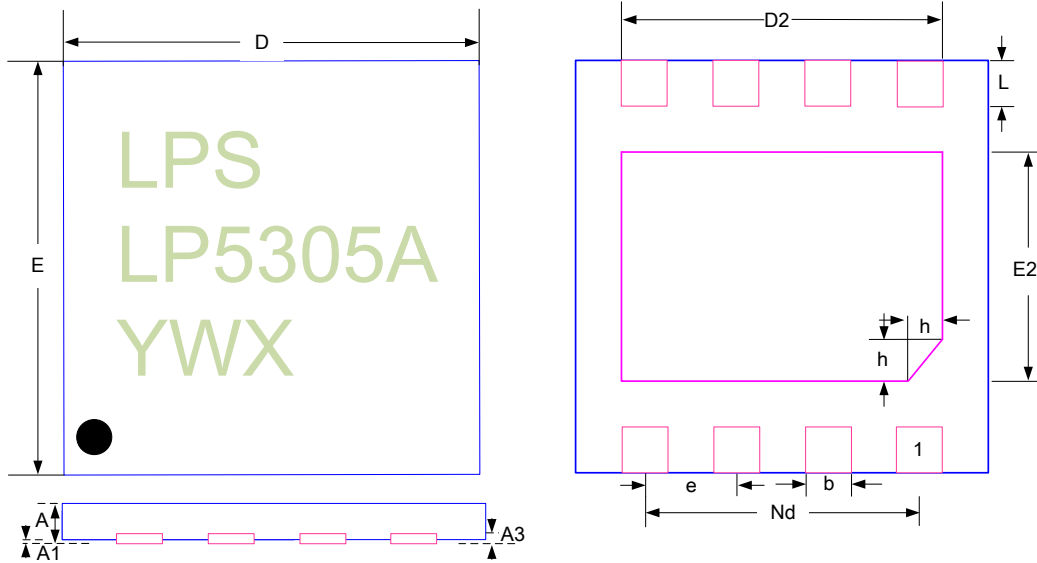

Figure 4. Recommended PCB Layout Diagram



## Outline Information

DFN-8 Package (2x2) pitch 0.5 (Unit: mm)



SYMBOL	DIMENSION IN MILLIMETER		
	MIN	NOM	MAX
A	0.450	0.500	0.550
A1	---	0.020	0.050
A3	0.180	0.200	0.250
b	0.200	0.250	0.300
D	1.900	2.000	2.100
D2	1.500	1.600	1.700
E	1.900	2.000	2.100
E2	0.800	0.900	1.100
e	0.500 BSC		
Nd	1.500 BSC		
L	0.250	0.300	0.350
h	0.150	0.200	0.250